



Perma-Crimp™ Hydraulic Hose Crimpers

PC200M Series Operators Manual

Including PC200M-1P and PC200M-3P



SAFETY PRECAUTIONS



- READ INSTRUCTIONS AND IDENTIFY ALL COMPONENT PARTS BEFORE USING CRIMPER.
- CRIMPER CAN PRODUCE 340 TONS OF FORCE. KEEP BOTH HANDS AWAY FROM PINCH POINTS.
- CONSULT THE CONTINENTAL CONTITECH CRIMP SPECIFICATION MANUAL FOR CORRECT CRIMPER SETTINGS AND CRIMP MEASUREMENTS.
- ALWAYS WEAR EYE PROTECTION.

Equipment Warning

Proper assembly of Continental ContiTech hose and fittings

Continental ContiTech hose, fittings and crimping equipment work together to provide an efficient and reliable hose connection. Continental ContiTech hose and fittings are part of an engineered system and are to be used in accordance with Continental ContiTech specifications. Using non-Continental ContiTech components may produce an assembly that does not meet rated performance. **Continental ContiTech does not warrant, expressly or by implication, hose assemblies that do not incorporate Continental ContiTech hose and fittings, or are not crimped in accordance with Continental ContiTech process specifications.**

Buyers may elect to attach additional or non-standard parts or equipment, or to use different manufacturing specifications as necessary to meet the requirements of the buyer or the customer's application. In such cases, the buyer has sole responsibility to qualify the hose for the applications as necessary to ensure performance capability.

For guidance in the assembly of Continental ContiTech hose and couplings, please refer to the Continental ContiTech Crimp Specifications Manual. Information in this catalog is believed to be accurate, but is not warranted and is subject to change without prior notice. For the most current product information, check the Continental ContiTech website at www.contitech.us.

For technical assistance, call customer service at **1-800-235-4632**.

SAFETY PRECAUTIONS-----	2
EQUIPMENT WARNING-----	2
COMPONENT IDENTIFICATION-----	4
FOOT SWITCH OPEN / CLOSE FUNCTION-----	5
CRIMPER SPECIFICATIONS-----	6
CRIMPER SPECIFICATIONS-----	5
DIE PART IDENTIFICATION-----	7
INITIAL CRIMPER SETUP-----	8
INTERMEDIATE DIE INSTALLATION-----	9
HYDRAULIC DIE INSTALLATION-----	10
MANUAL BACK STOP SETUP-----	11
CALIBRATION CHECK-----	12
LUBRICATION PROCEDURE & MAINTENANCE-----	13
TROUBLESHOOTING-----	14
WARRANTY INFORMATION-----	15

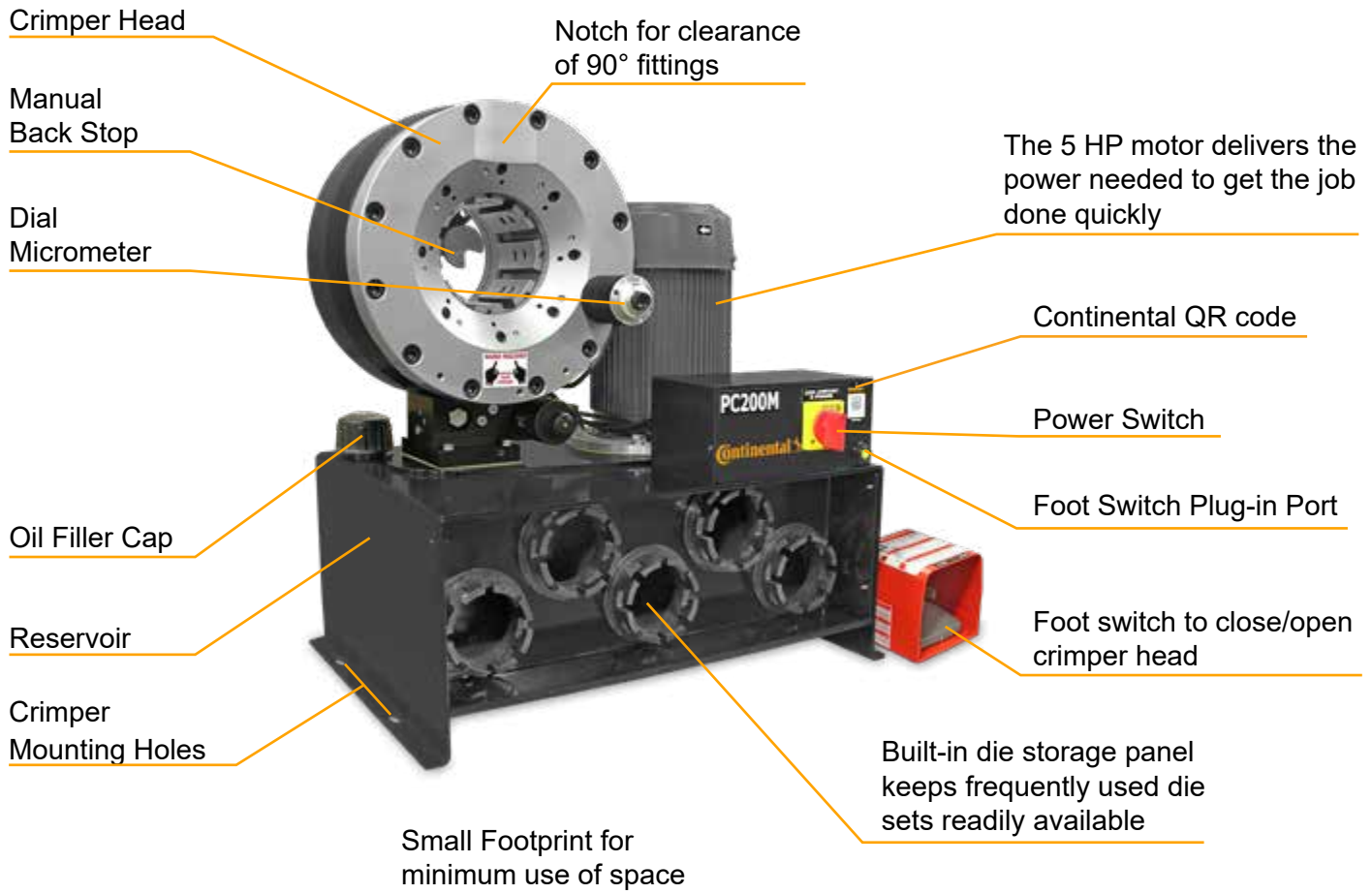

Foot Switch Plug-in Port



Serial Tag Location



Oil Level Sight Glass

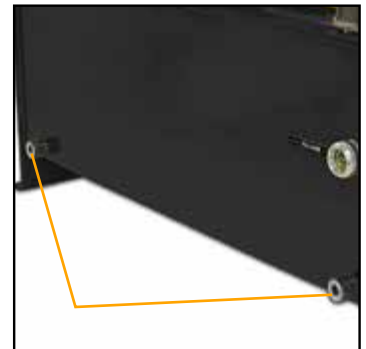

Reservoir Drain Ports

Do not operate the Continental PC200M crimper until you have read and fully understand this manual and the proper use of the crimper. This manual is applicable to the PC200M-1P and PC200M-3P crimpers. Crimpers are identical in component and crimping procedures. Note that the PC200M-1P and PC200M-3P require different electrical hookups as power requirements differ from 230V to 480V, respectively.

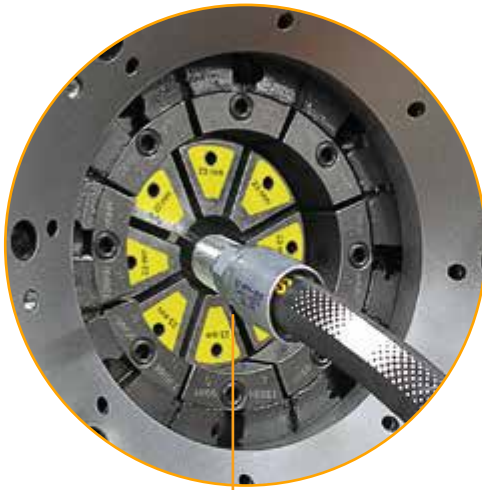

Foot Switch Close Function:

The foot switch permits dies to be “jogged” into position and accurately position the fitting prior to crimping.



Foot Switch Open Function:

Allows the user to open the crimper head the amount needed to remove the crimped assembly.



The foot switch allows the user to operate the crimper head, while keeping both of their hands free to provide a quick and accurate crimp. Keeping both hands free the user can make crimps fast, accurate and much easier.

Crimping Force..... 340 Tons
 Hydraulic Hose Capacity..... ¼" through 2" ID, 2-braid hose
 2" 6-spiral hose
 Crimper Dimensions..... L: 20" x W: 29" x H: 32"
 Crimper Weight..... 635 lbs.
 Electrical Requirements..... 230V - 1PH (Standard)
 230V - 3PH (Optional)
 480V - 3PH (Optional)
 Hydraulic Die Series..... PC200
 Adapter Die Series..... 130mm OD to 99mm ID
 Adjustability..... Metric Dial Micrometer
 Opening w/o Dies..... 160mm / 6.30"
 Master Die Inside Diameter..... 130mm / 5.12"
 Master Die Travel..... 38mm / 1.5"
 Motor..... 5HP
 Reservoir Capacity..... 8 US Gallons
 Oil Type..... ISO 46 Hydraulic Oil



Standard Dies			
Part #	ID	Part #	ID
PC200-8.5	8.5mm	PC200-41	41mm
PC200-12	12mm	PC200-45	45MM
PC200-14	14mm	PC200-50	50MM
PC200-16	16mm	PC200-56	56MM
PC200-19	19mm	PC200-62	62MM
PC200-23	23mm	PC200-69	69MM
PC200-27	27mm	PC200-74	74MM
PC200-31	31mm	PC200-78	78MM
PC200-34	34mm		



Miscellaneous Parts

PC200-MBS – Included Manual Back Stop
PC900-Aerosol Lube – Available High Pressure Grease in aerosol can
PC200-Rack – Available Black Die Cabinet, mounts below PC200M crimper
PC200-Rack Dimensions – 20" deep x 30" wide x 29" high



PC200-Rack
for PC200M Crimper

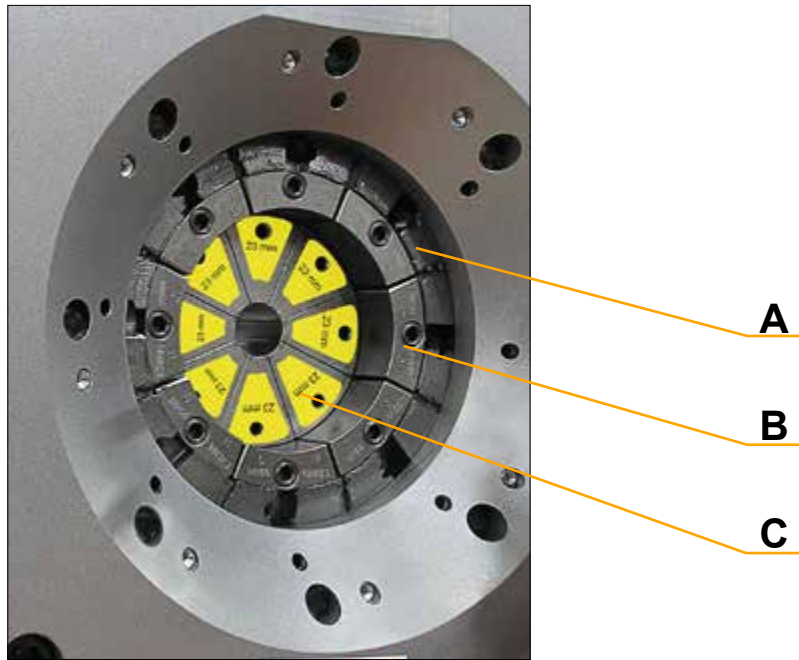

C) 99mm Hydraulic Die



B) 130mm O.D to 99mm I.D Adapter Die



A) Master Die



Follow these steps before using the crimper for the first time

- › Review instructions and identify all component parts before using crimper.
- › Crimper can produce 340 tons of force.
- › Keep both hands away from pinch points.
- › Consult the Continental ContiTech Crimp Specification Manual for correct crimper settings and crimp measurements.
- › Always wear eye protection.

Installing crimper

- › Mount the crimper on a sturdy surface. Workbench should be able to support crimper weight of 635 lbs. Crimper can be mounted to optional die cabinet, which is designed to support the unit. Do not lift machine by the crimper head. Using a fork lift, lift the crimper under the tank.

- › Check reservoir oil level with sight glass at the rear of the crimper. The reservoir requires 8 gallons of ISO 46 hydraulic oil for a complete fill. If necessary, oil can be drained from either of the two ports at the bottom of the reservoir.

- › Check electrical circuit to be certain that it matches the crimper requirements shown on the tag attached to the crimper cord.

› Electrical Requirements

- 230V - 1PH - 30 Amp
- 230V - 3PH - 20 Amp
- 480V - 3PH - 20 Amp

- › Make certain that the motor rotates in the direction of the arrow shown on the motor housing. If the motor rotation is opposite the direction of the arrow, reverse any two hot wires in the electrical plug of a 3 phase circuit. Damage to the pump can result if the motor does not rotate in the correct direction.



#1



#2



#3



#4

Both industrial and hydraulic dies are available for this crimper. Industrial dies are inserted directly into the master dies and hydraulic dies require an intermediate die. When using only hydraulic dies, removal of the intermediate dies should not be required.

The ID of the intermediate die must match the OD of the hydraulic die, or accurate crimps are not possible.

Installation or removal of intermediate dies

- › Turn on the crimper at the master power switch.
- › Bring the master dies to the full open position as shown in photo #1, or to the position where the die removal tool can be inserted to release the retaining spring.
- › Insert the die removal tool in the release hole to release the retaining spring as shown in photo #2.
- › Attach either an Intermediate Adapter Die or an Industrial Die to the Master Die as shown in photo #3.

Note: The numbers stamped on the face of the die should face the operator.

Note that on some crimpers the master dies must be slightly closed in order to completely insert the die removal tool.

- › Mount all 8 dies in a similar manner as shown in photo #4.
- › If Hydraulic Dies are being used, see Hydraulic Die Installation instructions.

#1



#2



#3



#4



› Install Intermediate Adapter Dies as shown previously making certain that the Intermediate Adapter Die I.D. matches the Hydraulic Die O.D.

› Bring the crimper head to fully opened position as shown in photo #1.

› Install the Hydraulic Dies with the quick change tool as shown in photo #2.

Note: The die size stamped on the face of the die should face toward the operator.

› Align the studs of the Hydraulic Dies with the holes in the Adapter Dies and **SLOWLY** close the crimper head on the die set as shown in photo #3.

› Bring the crimper head to a fully closed position as shown in photo #4.

› Remove the quick change tool as shown in photo #5.

Note: The dies may also be inserted manually with the crimper head in the fully open position.

› Proceed to the Crimping Instructions to set up the crimper for the hose and fitting being crimped.

› For Hydraulic Die removal, bring the crimper head to the fully closed position. Insert the quick change tool and open the crimper head, releasing the hydraulic dies from their spring retention holes.

#1



#2



#3



#4

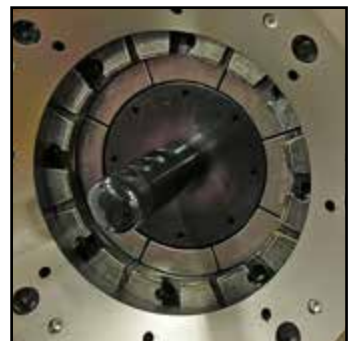

#5

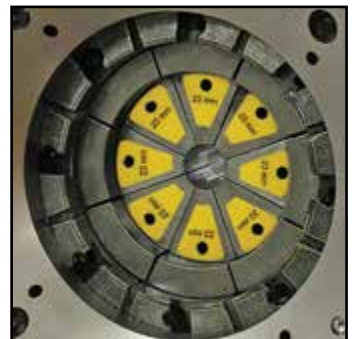

The Manual Back Stop eliminates guesswork, allowing the operator to visually observe exactly where the crimp will be positioned on the fitting without the need for trial and error and product scrap due to poor crimp positioning.

With the Manual Back Stop retracted, load the appropriate set of dies and set crimp diameters as required.

With the dial micrometer at 0, bring the dies to a fully closed position.

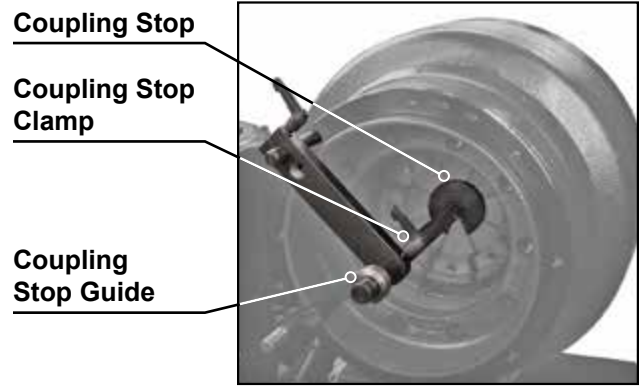

Loosen the Coupling Stop Clamp and position the Coupling Stop against the back face of the dies.



Slide the Coupling Stop Guide against the Coupling Stop Arm.



Hold the fitting against the Coupling Stop Arm withdraw the Coupling Stop Rod such that the Guide is aligned with the desired crimp position. Lock the Coupling Stop Clamp.



Position the fitting against the Coupling Stop and actuate the crimper in the normal manner.



The dimension from the face of the fitting to the crimp position will now be the dimension established in the previous step.

The PC200M Crimper is calibrated at factory using the correct hose, fitting, and die set outlined in the Continental ContiTech Crimp Specifications Manual.

Note: All settings are approximate, for minor adjustment adjust the dial as needed.

Due to variations in hose and fitting tolerances, some “offset” may be required to achieve the correct crimp diameter for specific hose and fitting combinations across the range of hose and fittings being crimped. If crimp diameters are consistently too large or consistently too small, the crimper should be recalibrated.

For example, with a 50mm die set installed and the Micrometer set at 250, the finished crimp diameter would be 52.5mm. (50mm + 2.5mm).

Step 1. Select the correct hose, fitting, and die set.

Note: Refer to the Continental ContiTech Crimp Specifications Manual.

Note: While the crimper can be calibrated using any recommended hose and fitting combination, using a hose and fitting combination close to the size most frequently crimped will minimize the offset required for other sizes and combinations of hose and fittings.

Step 2. Set the dial micrometer to the setting as shown in the most current Continental ContiTech Crimp Specifications Manual for the combination of hose and fitting being crimped.

Step 3. Check the crimp diameter of the finished assembly with calipers or micrometers, to be certain that it is within the specifications as outlined in the Continental ContiTech Crimp Specification Manual.

Calibration

Note: If the above conditions are not met, the crimper requires recalibration.

- › Make a crimp with the hose and fitting combination most commonly used, and measure the finished crimp diameter.
- › If necessary, loosen the set screw on the adjustment knob with a .050” hex key wrench.
- › Rotate the adjustment knob so that the number on the dial matches the actual diameter of the finished crimp.
- › Tighten the set screw and make another crimp to confirm that the crimper is set correctly.



Notes:

- › Use the mini grease gun with flush fitting adapter with grease (supplied with the crimper) as shown in photo #1 or a high-pressure moly grade grease can be used as well.

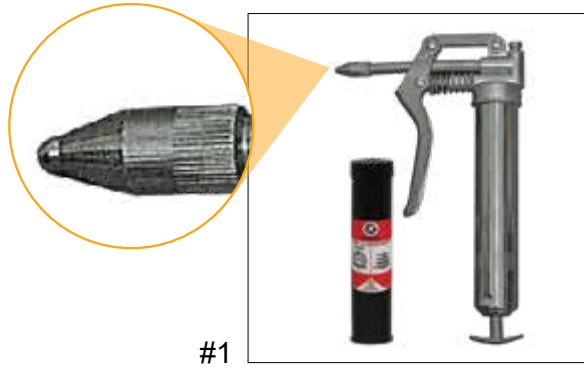

- › Failure to lubricate the crimper can cause premature failure, loss of accuracy and may result in damage to the crimper.
- › Lubricate the crimping head after each 250 - 400 crimping cycles or at the start of each shift if the crimper is used in a production setting.

To begin, first bring the master dies to the fully opened position, as shown in photo #2.

Lubricate the master dies through the 8 lubrication fittings in the front flange face (as shown in photo #3).

Next, bring the master dies to the fully closed position, and lubricate the master dies through the 8 lubrication fittings again (as shown in photo #4).

Notes:

- › Parking the crimper in the fully open position when is not in use will prolong the life of the master die springs.
- › **The Front Flange Bolts:** Shown in photo #5 periodically, every 6-12 months depending upon usage, the bolt torque should be checked. The correct torque is 332NM (245 Ft-Lbs).
- › **The Protective Master Die Foam Pads:** Periodically you need to check them for dirt, oil, and other debris. The protective pads (as shown in photo #6) should be replaced if damaged, missing, or not retracting properly.

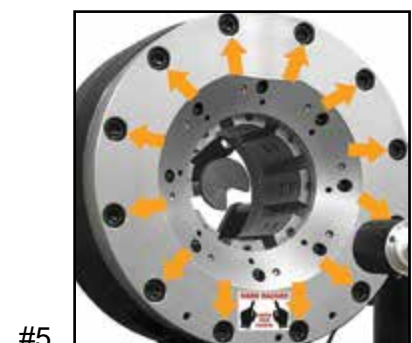
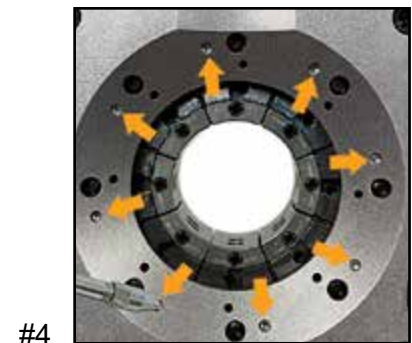
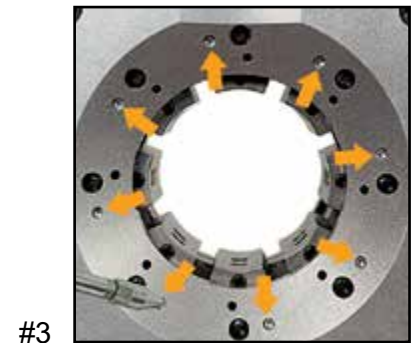
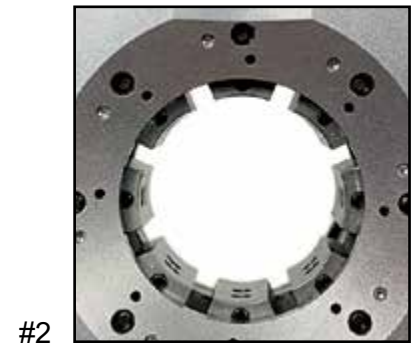

PROBLEM: CRIMPER RUNS BUT IS SLOW OR NON-FUNCTIONAL

- Check supply voltage to see that it matches the voltage specified on the tag attached to the crimper.
- If the crimper is connected to a three phase circuit, check all three legs of the circuit to be certain that all legs are hot.
- Measure the voltage to the crimper when the crimper is under load. Voltage should be a minimum of 90% of line voltage when the crimper is under load.

Note: Many performance problems are the result of low voltage or inadequate electrical service.

- Check motor rotation and be certain that the motor rotates in the direction of the arrow on the motor housing. For three phase units rotation can be reversed by switching any two wires in the plug.
- The circuit in the crimper is protected by a thermal overload relay. If the relay trips after resetting it from the master power switch, call for technical service.

PROBLEM: MOTOR RUNS BUT FOOT SWITCH WILL NOT OPERATE

- Power to the secondary circuit is supplied from a 24 volt step down transformer. If the motor runs normally but the foot switch will not function check the 2 amp slo blow fuse located in the control box as shown in the photo below.

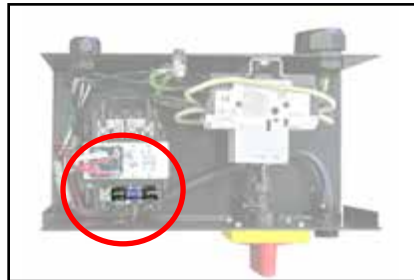

PROBLEM: CRIMPER WILL CLOSE ON FITTING BUT DOES NOT DEVELOP POWER TO COMPLETE THE CRIMP

- Fitting is too large for selected crimp die. Select a crimp die that is closer to final crimp diameter. Machine has built-in safety bypass to protect internal components from damage due to incorrect die selection.
- Check oil level. Position dies to the fully open position and check oil sight gage in rear of machine. Be sure the oil level is in the middle of the sight glass. Use ISO 32 or 46 weight hydraulic oil.

If problem(s) persist contact Customer Service for additional troubleshooting assistance

For technical assistance, call customer service at **1-800-235-4632**. The Continental ContiTech branded crimper is covered under the warranty below.

CustomCrimp® “No Nonsense” warranty

All CustomCrimp® products are warranted to be free of defects in workmanship and materials for one year from the date of invoice. This warranty ends when the product becomes unusable for reasons other than defects in workmanship or material.

If any product or part manufactured by CustomCrimp® is found to be defective by CustomCrimp®, at its option CustomCrimp® will either repair or replace the defective part or product and return via ground transportation, freight prepaid.

This warranty does not cover any product or part which is worn out, abused, altered, used for a purpose other than for which it was intended or used in a manner which was inconsistent with any instructions regarding its use.

Electric motors are separately warranted by their manufacturer under the conditions stated in their separate warranty.

Contact

ContiTech AG
NAFTA Headquarters
703 S. Cleveland Massillon Road
Fairlawn, OH 44333-3023 U.S.A.
1-800-235-4632

Canada

1-888-275-4397
FAX 1-888-464-4397

Mexico

1-800-439-7373
FAX 1-800-062-0918

Germany

+49 (0)511 938 02
mailservice@contitech.de

www.continental-industry.com

As a division of the Continental Group, ContiTech is a recognized innovation and technology leader in natural rubber and plastics. As an industry partner with a firm future ahead of us, we engineer solutions both with and for our customers around the world. Our bespoke solutions are specially tailored to meet the needs of the market. With extensive expertise in materials and processes, we are able to develop cutting-edge technologies while ensuring we make responsible use of resources. We are quick to respond to important technological trends, such as function integration, lightweight engineering and the reduction of complexity, and offer a range of relevant products and services. That way, when you need us, you'll find we're already there.